

INSTALLATION INSTRUCTIONS

T-LEG SPANNER

T-LEG SPANNER (CD451_)

- See pages 4 to 8 for installation instructions.
- For use with mobile T-LEG systems, with and without backs
- EMPs may only be used in certain cases with a T-LEG SPANNER.
- See illustration for correct applications:

CD451_ W/EMPs

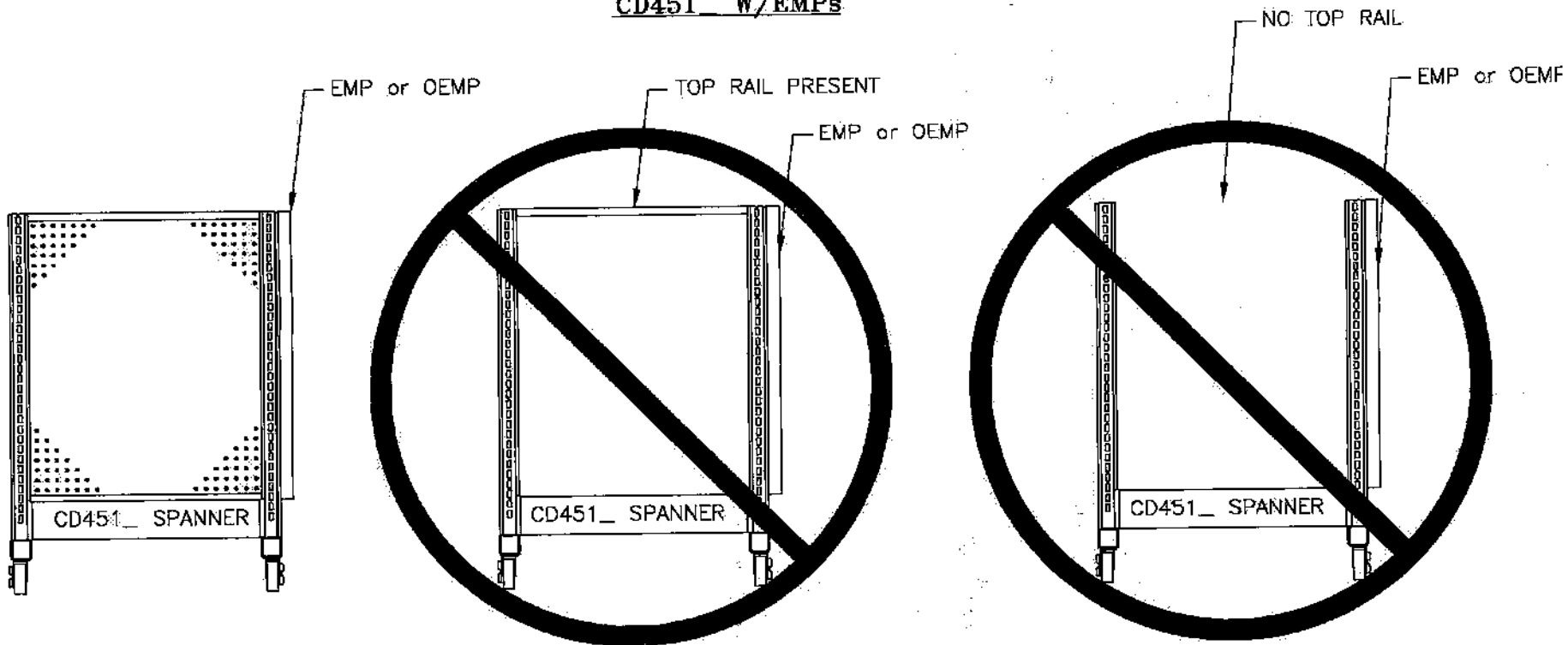

SPANNER WITH
BACKS AND RAILS.
MAX LOAD PER EMP: 400 LBS.

SPANNER WITH
RAILS, NO BACKS.
UNSAFE

SPANNER WITH
NO RAILS, NO BACKS
UNSAFE

LOZIER

© 2014 LOZIER CORPORATION

6336 PERSHING DRIVE
OMAHA, NEBRASKA 68110
(800) 228-9882

82669 REV. L
OMPCOA-19 02-19-14
PAGE 1 OF 11

INSTALLATION INSTRUCTIONS

OPEN BACK SPANNER SYSTEMS

OPEN BACK SPANNER (OBS_)

- See pages 9 to 11 for installation instructions.
- Typically used in open back systems, however special height backs may be used if desired.
- See illustrations below for correct applications.

OBS_ W/ EMPs

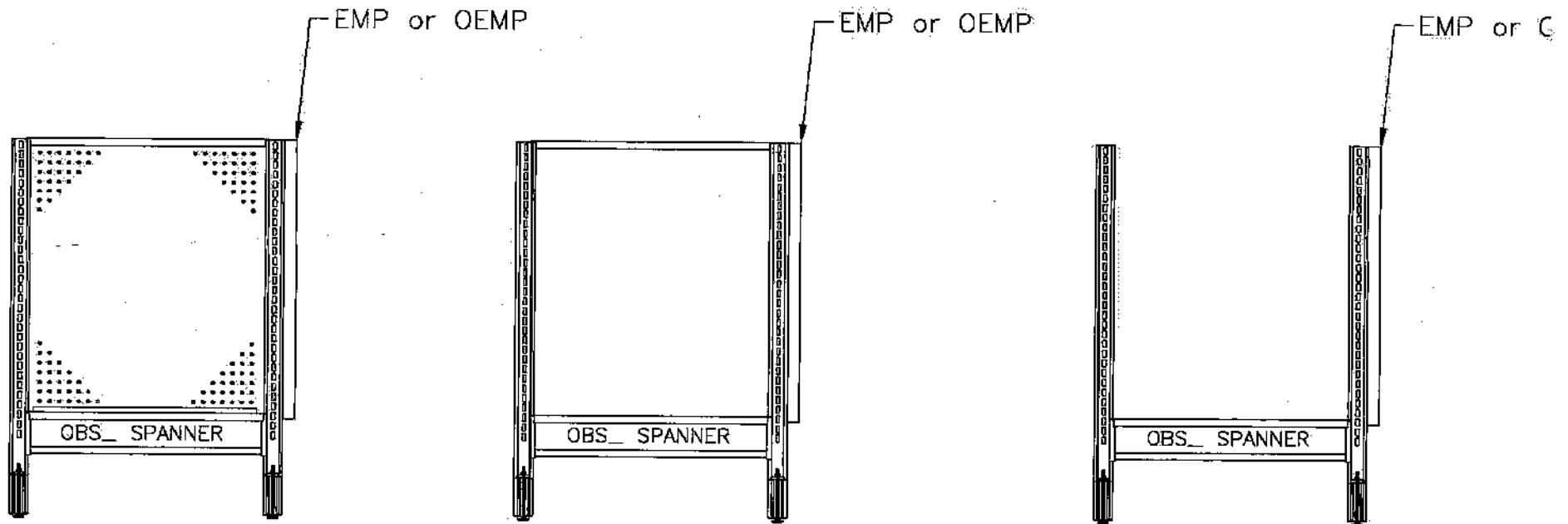

SPANNER WITH
BACKS AND RAILS.

MAX LOAD PER EMP: 400 LBS

SPANNER WITH BOLT-ON
RAILS, NO BACKS.

MAX LOAD PER EMP: 400 LBS

SPANNER WITH
NO RAILS, NO BACKS.

MAX LOAD PER EMP: 250 LBS

LOZIER

© 2014 LOZIER CORPORATION

6336 PERSHING DRIVE
OMAHA, NEBRASKA 68110
(800) 228-9882

82669 REV. L
OMPCOA-19 02-19-14
PAGE 2 OF 11

INSTALLATION INSTRUCTIONS

STABILITY OF SINGLE SECTION SYSTEMS WITH END FRAMES

Because bottom spanners create a rigid connection between uprights, there is a greater chance of the system flipping due to an unbalanced end load. To prevent this, certain precautions **MUST** be taken.

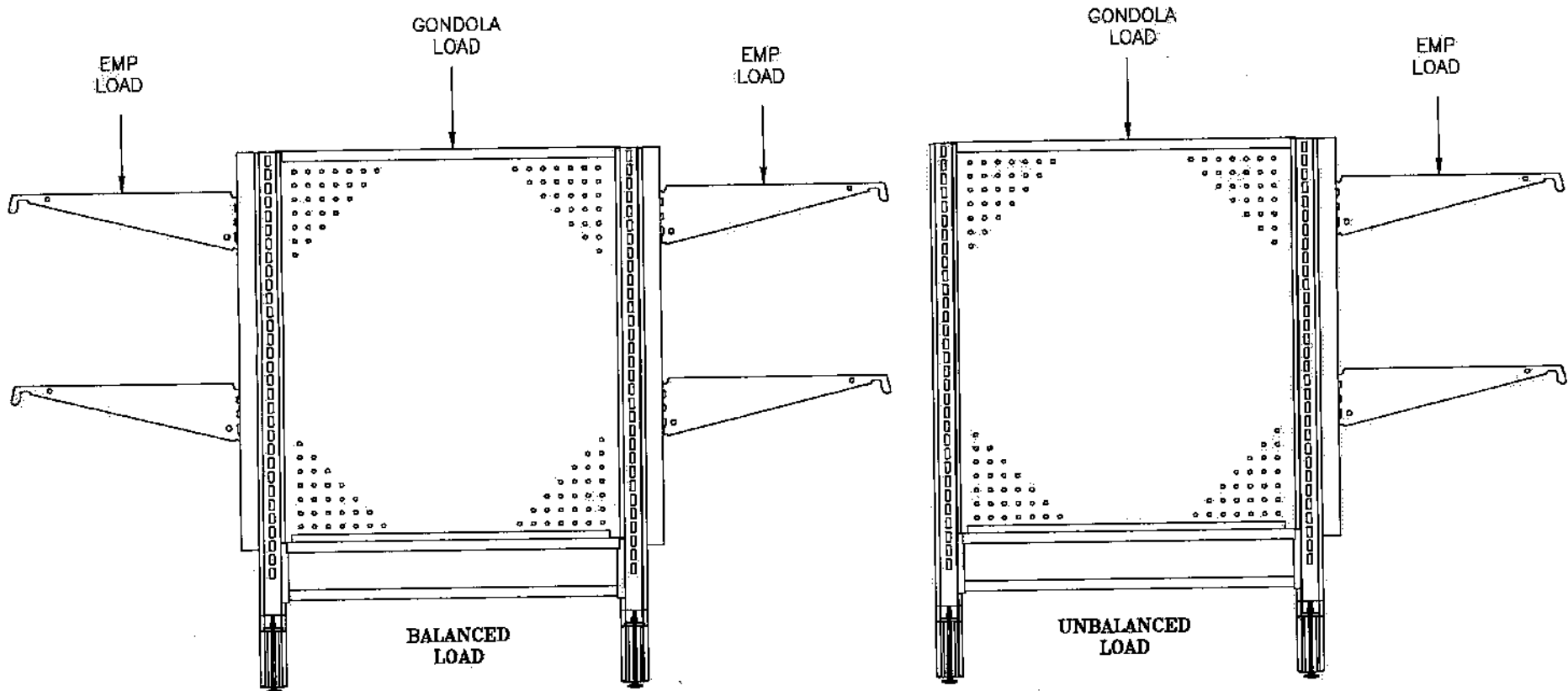

- The load on the gondola section **MUST** be 1.5 times greater than the load on the EMP, in the unbalanced situation.
- Load end displays last and unload first when changing merchandise, to ensure there is always enough counterweight to prevent tipping.

LOZIER

© 2014 LOZIER CORPORATION

6336 PERSHING DRIVE
OMAHA, NEBRASKA 68110
(800) 228-9882

82669 REV. L
OMPCOA-19 02-19-14
PAGE 3 OF 11

INSTALLATION INSTRUCTIONS

T-LEG SPANNER (SINGLE SECTION)

- STEP 1:** Fasten T-leg spanner between T-legs using carriage bolt & load spreader. Install bolt through lower hole in uprite and upper square hole in spanner. Secure bolts with lock washers and hex nuts. Do not over tighten.
- STEP 2:** Install bottom rail directly over spanner & install center rail approximately halfway up on uprite.

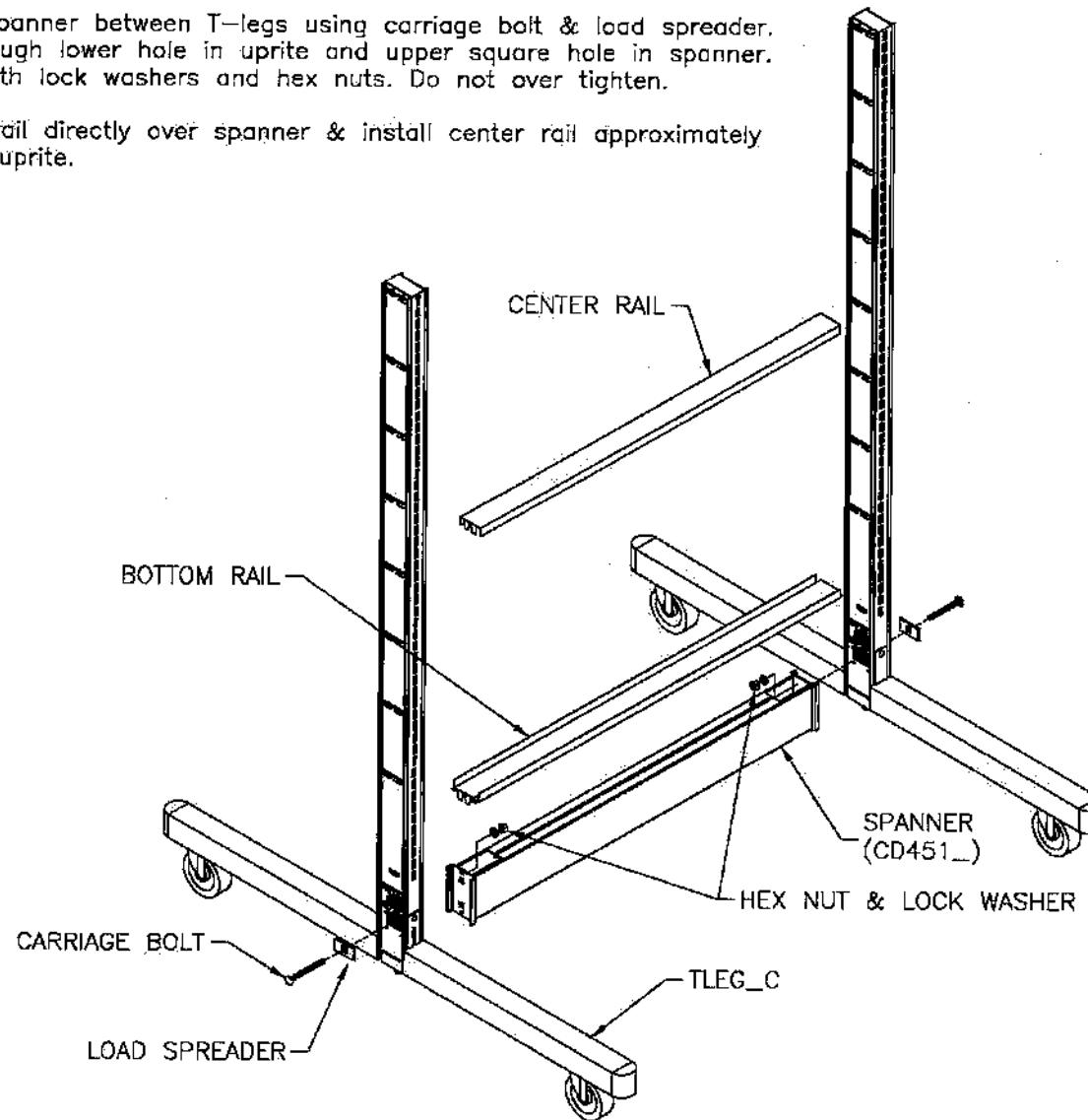

LOZIER

© 2014 LOZIER CORPORATION

6336 PERSHING DRIVE
OMAHA, NEBRASKA 68110
(800) 228-9882

82669 REV. L
OMP COA-19 02-19-14
PAGE 4 OF 11

INSTALLATION INSTRUCTIONS

T-LEG SPANNER (SINGLE SECTION)

- STEP 3:** Install backs and top rail.
- STEP 4:** Install uprite end trim.
- STEP 5:** Install special top rail, pg. 8.
(Bolt on stabilizer MUST be used)

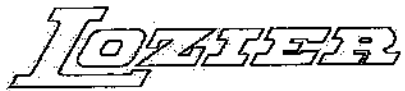
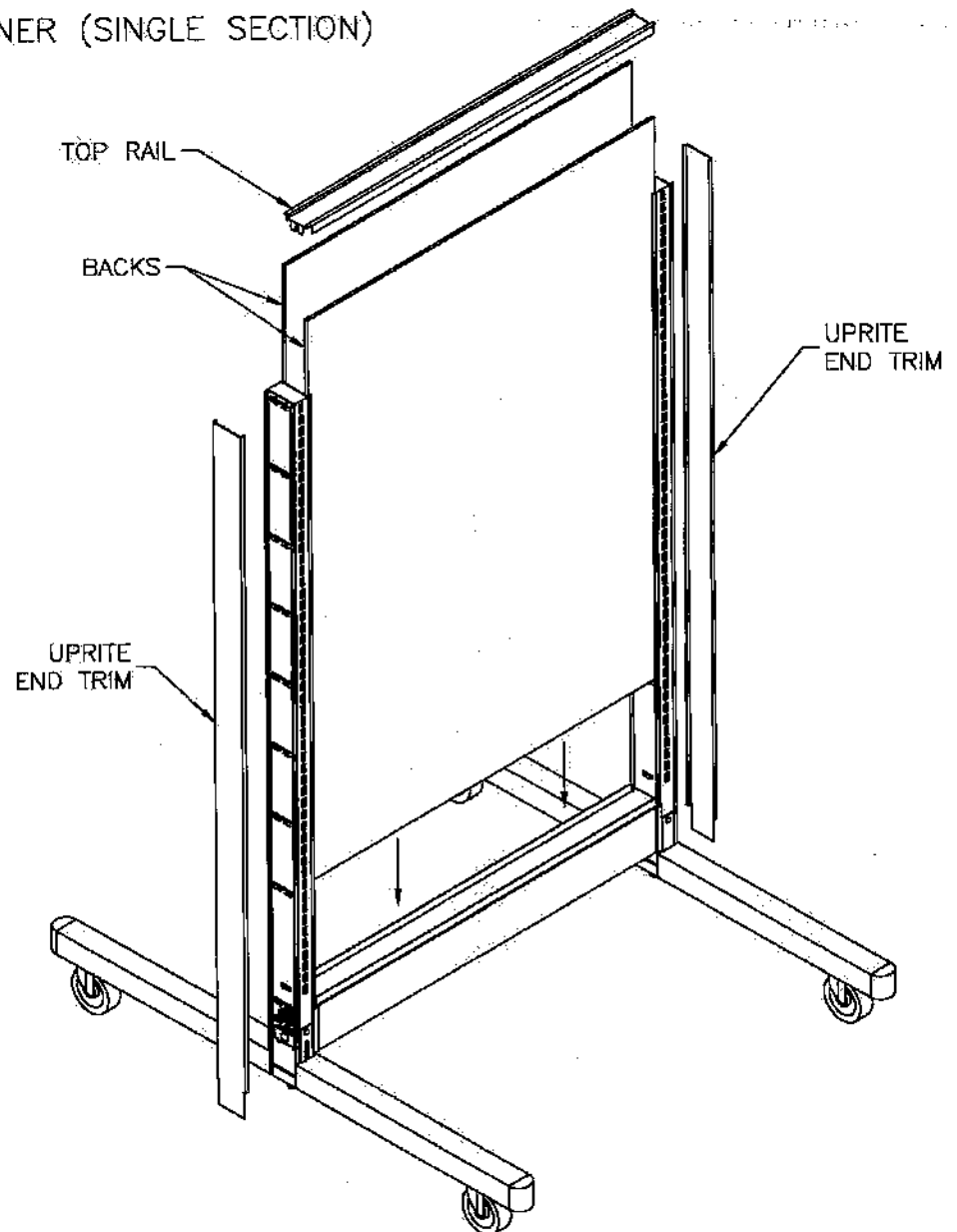

© 2014 LOZIER CORPORATION

6336 PERSHING DRIVE
OMAHA, NEBRASKA 68110
(800) 228-9882

82669 REV. L
OMPCOA-19 02-19-14
PAGE 5 OF 11

INSTALLATION INSTRUCTIONS

T-LEG SPANNER (MULTIPLE SECTIONS)

- STEP 1:** Fasten T-leg spanner to end T-legs using carriage bolt & load spreader. Install bolt through lower hole in upright and upper square hole in spanner. Secure square bolts with lock washer and hex nuts. Do not over tighten.
- STEP 2:** Fasten T-leg spanner to middle T-legs using carriage bolt. Install bolt through upper square hole in one spanner then the lower hole in the upright and through the upper square hole in the other spanner. Secure bolt with lock washer and hex nut. Do not over tighten. (Note: Load spreaders are not required on middle T-legs).
- STEP 3:** Install bottom rail directly over spanners & install center rails approximately halfway up on uprights.

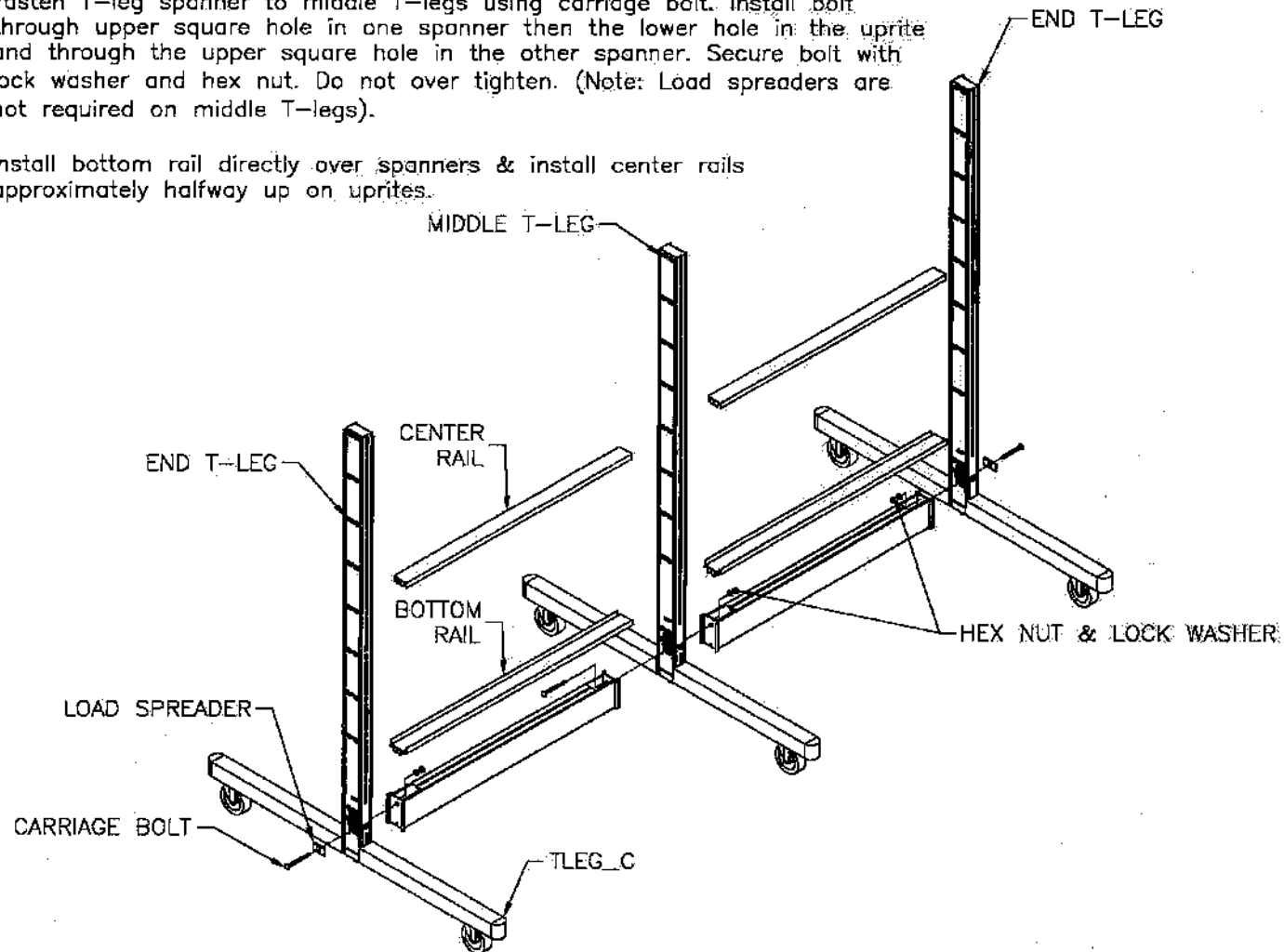

Lozier

© 2014 LOZIER CORPORATION

6336 PERSHING DRIVE
OMAHA, NEBRASKA 68110
(800) 228-9882

82669 REV. L
OMPCOA-19 02-19-14
PAGE 6 OF 11

INSTALLATION INSTRUCTIONS

T-LEG SPANNER (MULTIPLE SECTIONS)

STEP 4: Install backs and top rail.

STEP 5: Install uprite end trim. Install special top rail, pg. 8.
(Bolt on stabilizer MUST be used.)

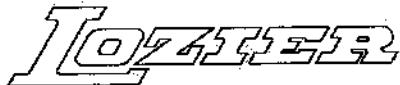
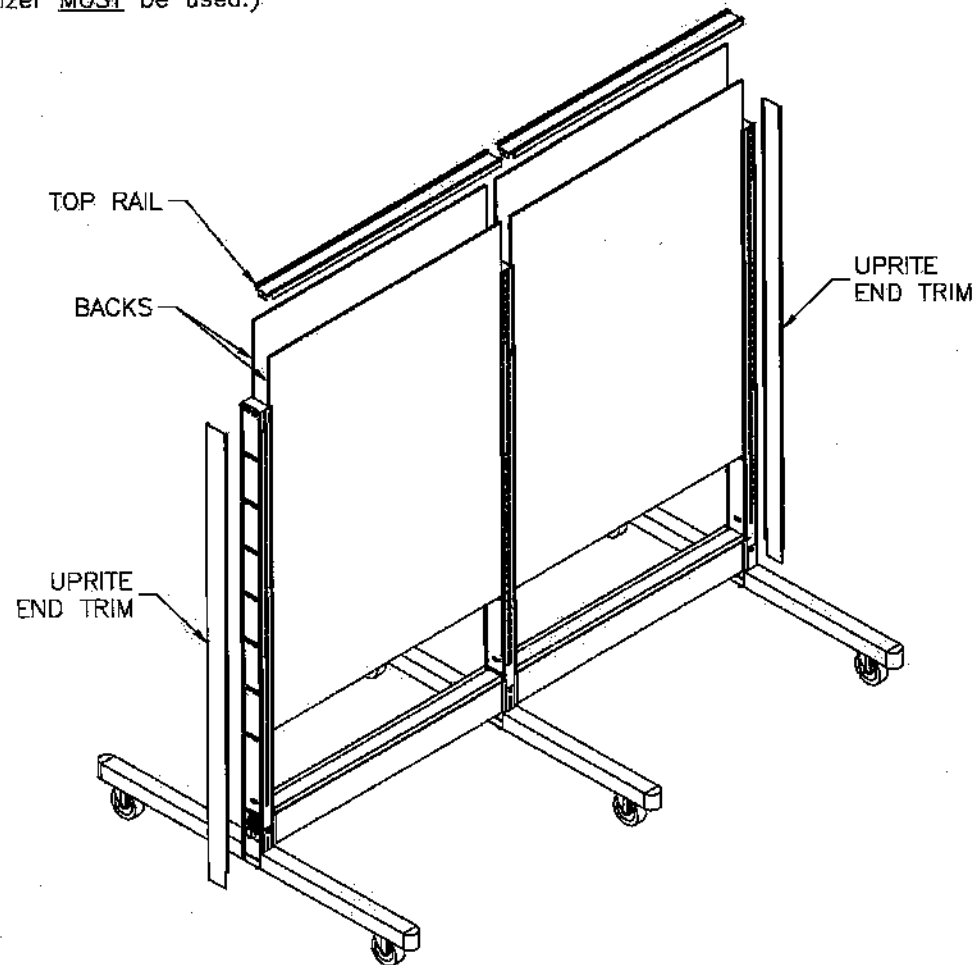

©2014 LOZER CORPORATION

6336 PERSHING DRIVE
OMAHA, NEBRASKA 68110
(800) 228-9882

82669 REV. L
OMPCOA-19 02-19-14
PAGE 7 OF 11

INSTALLATION INSTRUCTIONS

T-LEG SPANNER (SPECIAL TOP RAIL)

STEP 6: Carefully install the uprite inserts into the end uprites of the gondola until the tops of inserts and uprites are flush. The uprite inserts should snap into place and engage the second lance from the top of the uprites. (See FIGURE 1).

STEP 7: Position the top rail stabilizer over the top of the standard top rail and secure with 1/4-20 x 3/4 machine screw.

NOTE: For multiple sections in a run, ends of spanners will overlap

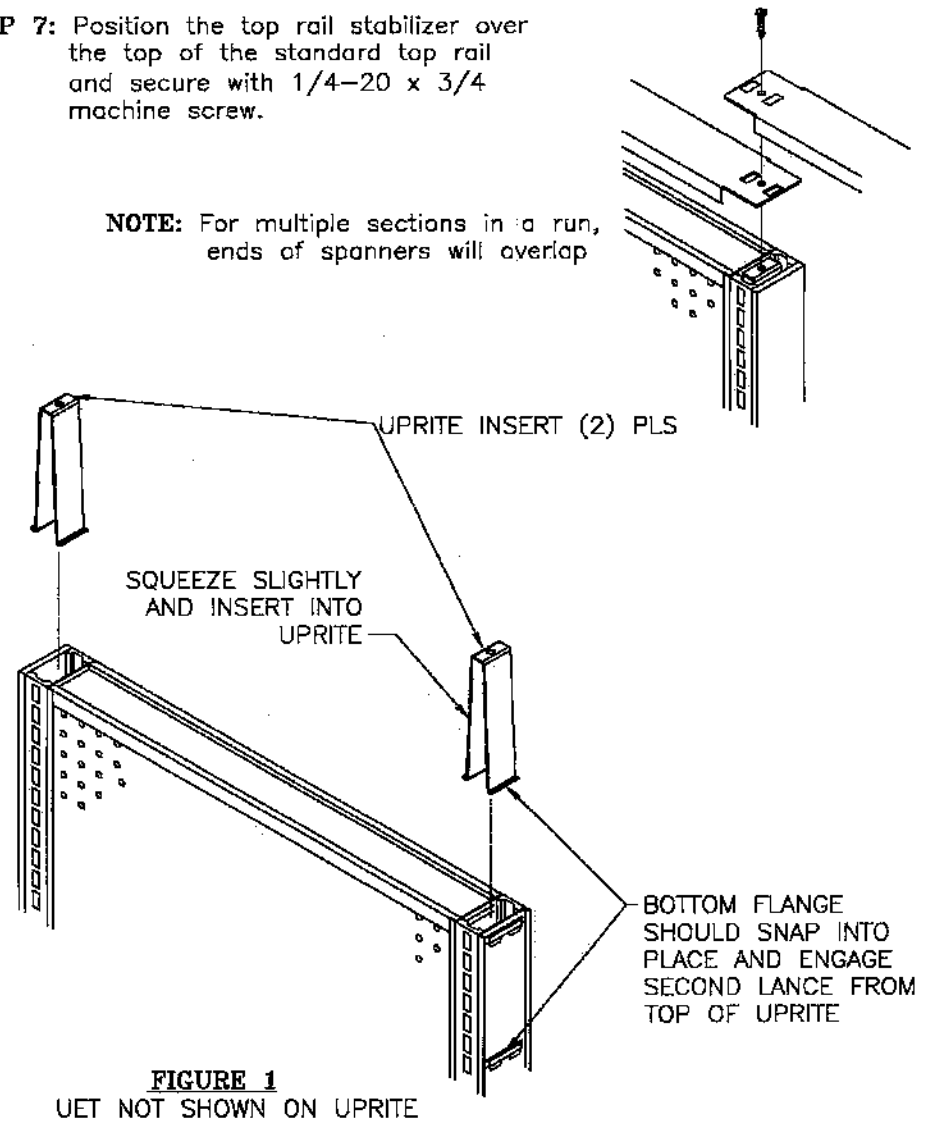
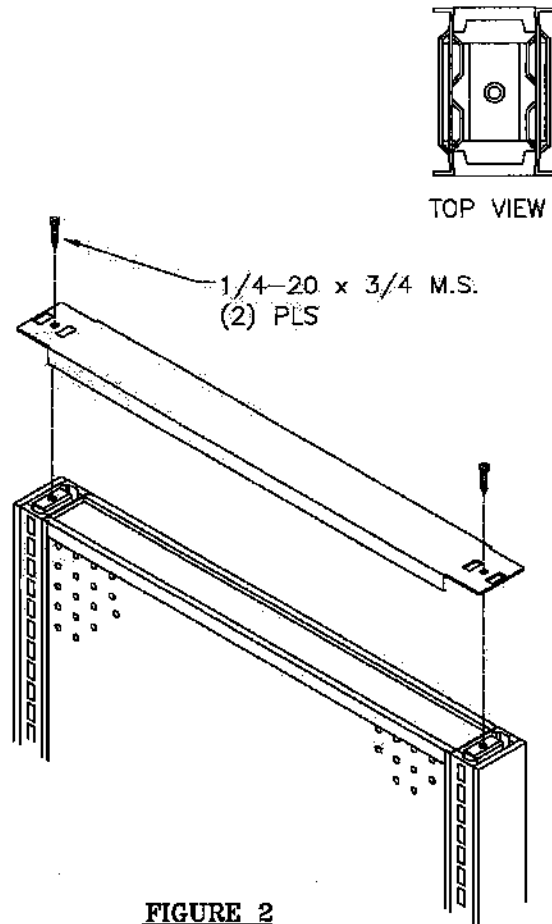

INSTALLATION INSTRUCTIONS

OPEN BACK SPANNER

- STEP 1:** Assemble Uprite & Base Brackets according to standard shelving instructions, 01-13.
- STEP 2:** Place Load Spreader over the round hole on the outside of the Uprite & insert a carriage bolt thru the Load Spreader & Uprite.
- STEP 3:** Align the square hole in the end of the Open Back Spanner with the bolt & slide onto bolt. Secure with a hex nut. Tighten FINGER TIGHT ONLY. (See FIGURE 3).
- STEP 4:** Place carriage bolt thru hole in the other end of Open Back Spanner. Stand next uprite assembly vertical & install onto bolt. Add next Open Back Spanner & secure with a hex nut. Tighten FINGER TIGHT ONLY. (See FIGURE 4)
- STEP 5:** For best results, level island run first then tighten bolts with a socket wrench.

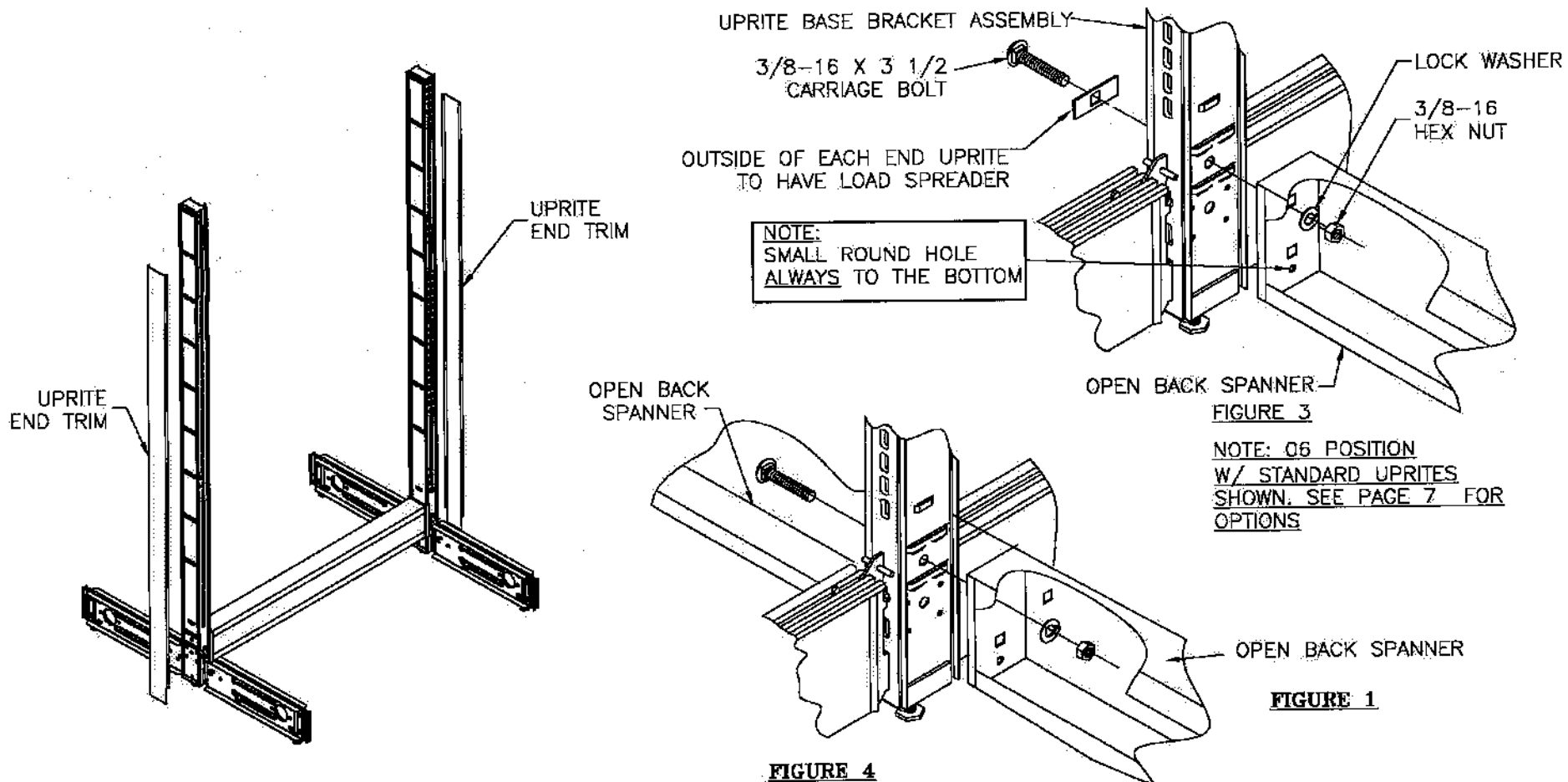

LOZIER

©2014 LOZIER CORPORATION

6336 PERSHING DRIVE
OMAHA, NEBRASKA 68110
(800) 228-9882

82669 REV. L
OMPCOA-19 02-19-14
PAGE 9 OF 11

INSTALLATION INSTRUCTIONS

OPEN BACK SPANNER

STANDARD UPRITE OPEN BACK SPANNER POSITIONS

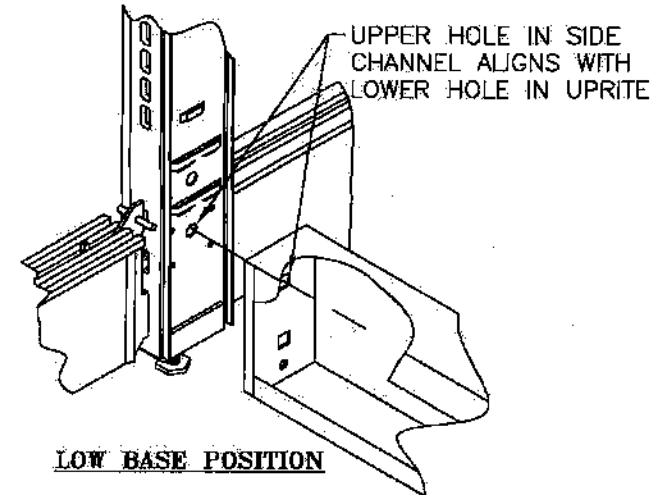
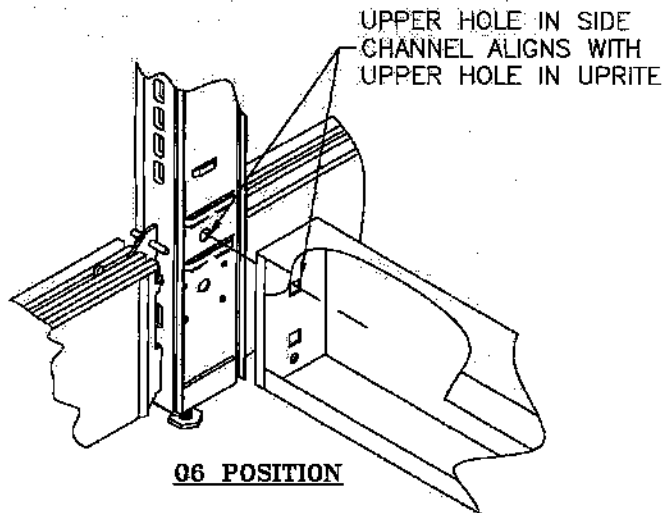

INSTALLATION INSTRUCTIONS

OPEN BACK SPANNER

REMOVABLE UPRITE SOCKET OPEN BACK SPANNER POSITIONS NO EMP'S ALLOWED WITH REMOVABLE UPRITE SOCKETS

